

# L7: Linear prediction of speech

**Introduction**

**Linear prediction**

**Finding the linear prediction coefficients**

**Alternative representations**

This lecture is based on [Dutoit and Marques, 2009, ch1; Taylor, 2009, ch. 12; Rabiner and Schaefer, 2007, ch. 6]

# Introduction

## Review of speech production

- Speech is produced by an excitation signal generated in the throat, which is modified by resonances due to the shape of the vocal, nasal and pharyngeal tracts
- The excitation signal can be
  - Glottal pulses created by periodic opening and closing of the vocal folds (voiced speech)
    - These periodic components are characterized by their fundamental frequency ( $F_0$ ), whose perceptual correlate is the pitch
  - Continuous air flow pushed by the lungs (unvoiced speech)
  - A combination of the two
- Resonances in the vocal, nasal and pharyngeal tracts are called formants

- On a spectral plot for a speech frame
  - Pitch appears as narrow peaks for fundamental and harmonics
  - Formants appear as wide peaks in the spectral envelope

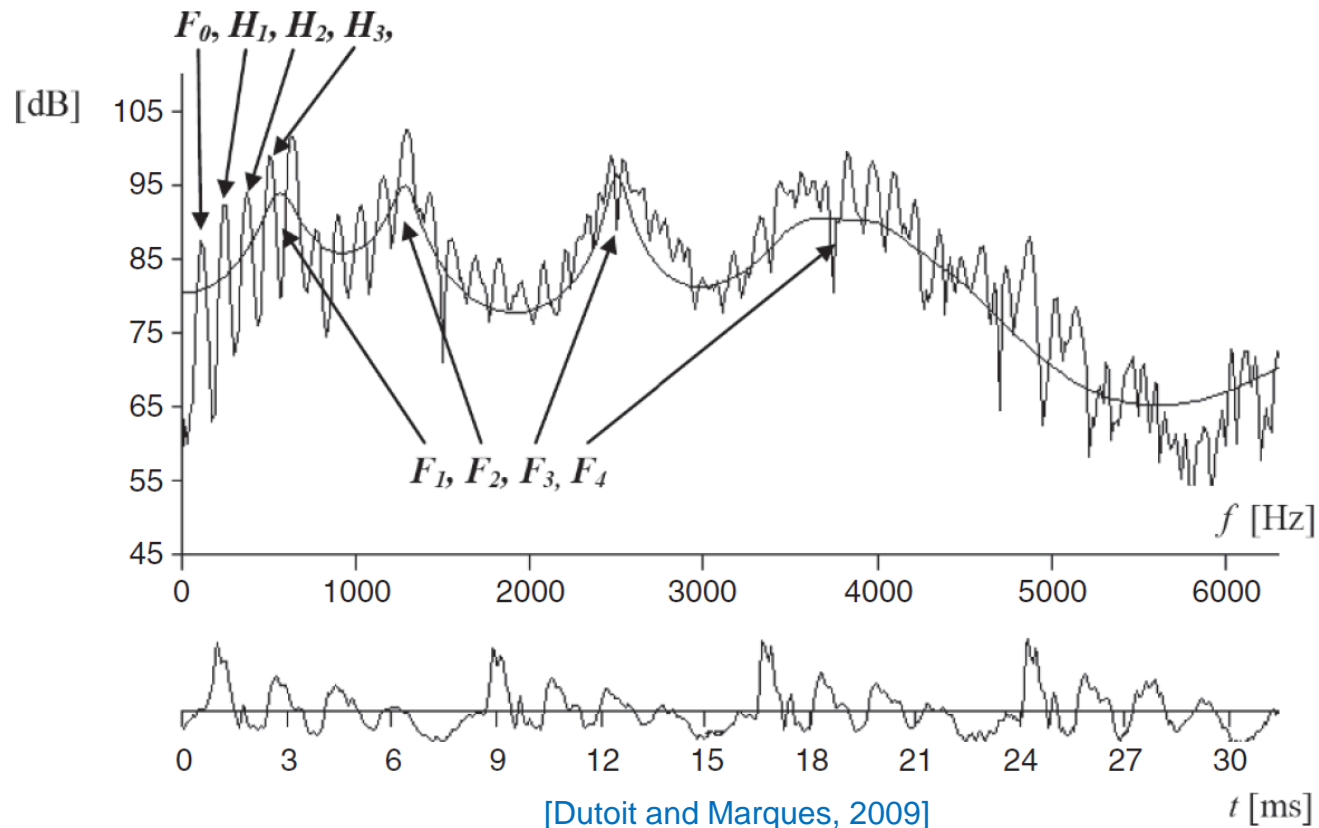

# Linear prediction

## The source-filter model

- Originally proposed by Gunnar Fant in 1960 as a linear model of speech production in which glottis and vocal tract are fully uncoupled
- According to the model, the speech signal is the output  $y[n]$  of an all-pole filter  $1/A(z)$  excited by  $x[n]$

$$Y(z) = X(z) \frac{1}{1 - \sum_{k=1}^p a_k z^{-k}} = X(z) \frac{1}{A_p(z)}$$

- where  $Y(z)$  and  $X(z)$  are the  $z$  transforms of the speech and excitation signals, respectively, and  $p$  is the prediction order
- The filter  $1/A_p(z)$  is known as the *synthesis filter*, and  $A_p(z)$  is called the *inverse filter*
- As discussed before, the excitation signal is either
  - A sequence of regularly spaced pulses, whose period  $T_0$  and amplitude  $\sigma$  can be adjusted, or
  - White Gaussian noise, whose variance  $\sigma^2$  can be adjusted

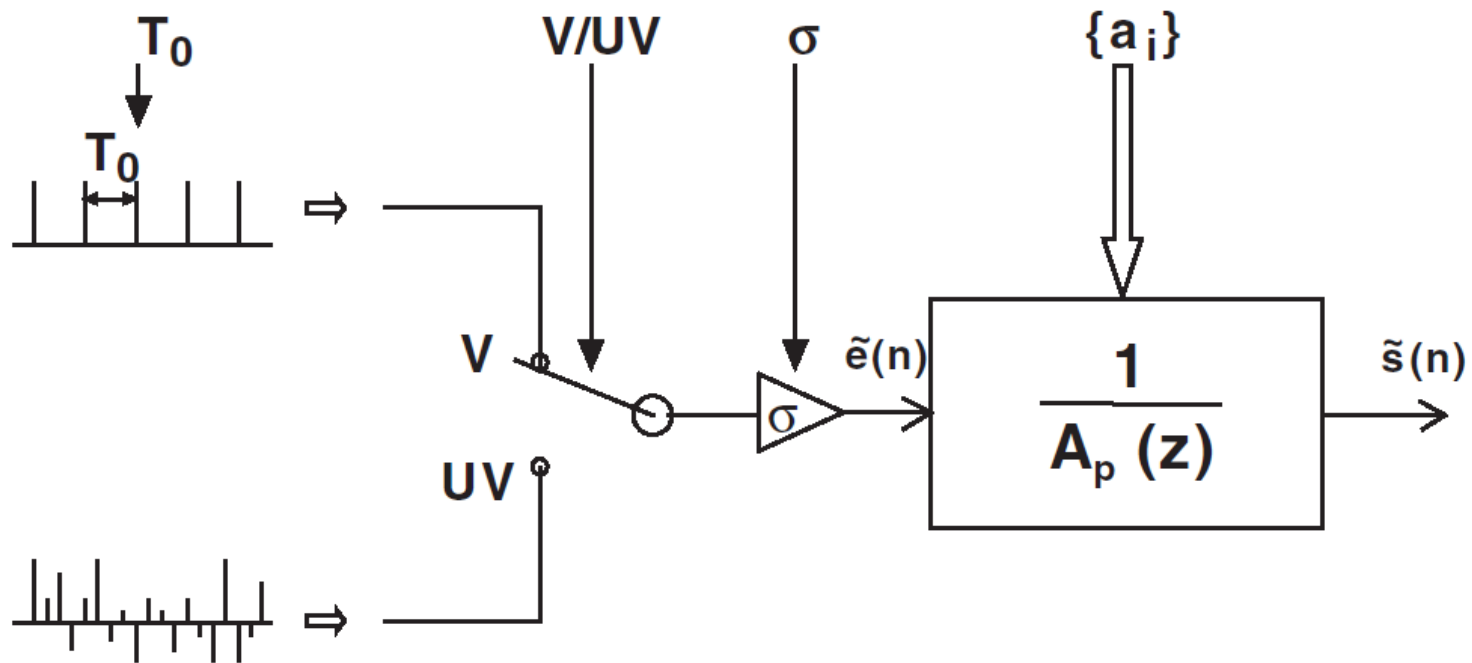

[Dutoit and Marques, 2009]

- The above equation implicitly introduces the concept of linear predictability, which gives name to the model
- Taking the inverse z-transform, the speech signal can be expressed as

$$y[n] = x[n] + \sum_{k=1}^p a_k y[n - k]$$

- which states that the speech sample can be modeled as a weighted sum of the  $p$  previous samples plus some excitation contribution
- In linear prediction, the term  $x[n]$  is usually referred to as the error (or residual) and is often written as  $e[n]$  to reflect this

## Inverse filter

- For a given speech signal  $x[n]$ , and given the LP parameters  $\{a_i\}$ , the residual  $e[n]$  can be estimated as

$$e[n] = y[n] - \sum_{k=1}^p a_k y[n - k]$$

- which is simply the output of the inverse filter excited by the speech signal (see figure below)
- Hence, the LP model also allows us to obtain an estimate of the excitation signal that led to the speech signal
  - One will then expect that  $e[n]$  will approximate a sequence of pulses (for voiced speech) or white Gaussian noise (for unvoiced speech)

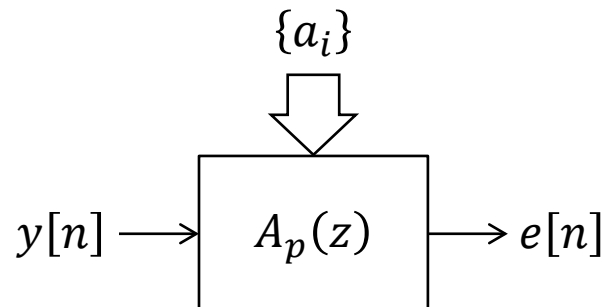

[Dutoit and Marques, 2009]

# Finding the LP coefficients

## How do we estimate the LP parameters?

- We seek to estimate model parameters  $\{a_i\}$  that minimize the expectation of the residual energy  $e^2(n)$

$$\{a_i\}^{opt} = \arg \min[e^2(n)]$$

- Two closely related techniques are commonly used
  - the covariance method
  - the autocorrelation method



## The covariance method

- Using the term  $E$  to denote the sum squared error, we can state

$$E = \sum_{n=0}^{N-1} e^2(n) = \sum_{n=0}^{N-1} \left( y[n] - \sum_{k=1}^p a_k y[n-k] \right)^2$$

- We can then find the minimum of  $E$  by differentiating with respect to each coefficient  $a_i$  and setting to zero

$$\begin{aligned} \frac{\partial E}{\partial a_j} = 0 &\Rightarrow \sum_{n=0}^{N-1} \left( 2 \left( y[n] - \sum_{k=1}^p a_k y[n-k] \right) y[n-j] \right) = \\ &= -2 \sum_{n=0}^{N-1} y[n]y[n-j] + 2 \sum_{n=0}^{N-1} \sum_{k=1}^p a_k y[n-k]y[n-j] = 0 \\ &\quad \forall j = 1, 2, \dots, p \end{aligned}$$

- which gives

$$\sum_{n=0}^{N-1} y[n]y[n-j] = 2 \sum_{k=1}^p a_k \sum_{n=0}^{N-1} y[n-k]y[n-j]$$

- Defining  $\phi(j, k)$  as

$$\phi(j, k) = \sum_{n=0}^{N-1} y[n-j]y[n-k]$$

- This expression can be written more succinctly as

$$\phi(j, 0) = \sum_{k=1}^p \phi(j, k)a_k$$

- Or in matrix notation as

$$\begin{bmatrix} \phi(1,0) \\ \phi(2,0) \\ \vdots \\ \phi(p,0) \end{bmatrix} = \begin{bmatrix} \phi(1,1) & \phi(1,2) & \dots & \phi(1,p) \\ \phi(2,1) & \phi(2,2) & \dots & \phi(2,p) \\ \vdots & \vdots & \ddots & \vdots \\ \phi(p,1) & \phi(p,2) & \dots & \phi(p,p) \end{bmatrix} \begin{bmatrix} a_1 \\ a_2 \\ \vdots \\ a_p \end{bmatrix}$$

- or even more compactly as  $\Phi = \Psi a$

- Since  $\Phi$  is symmetric, this system of equations can be solved efficiently using Cholesky decomposition in  $O(p^3)$

## – NOTES

- This method is known as the covariance method (for unclear reasons)
- The method calculates the error in the region  $0 \leq n < N - 1$ , but to do so uses speech samples in the region  $-p \leq n < N - 1$ 
  - Note that to estimate the error at  $y[0]$ , one needs samples up to  $y[-p]$
- No special windowing functions are needed for this method
- If the signal follows an all-pole model, the covariance matrix can produce an exact solution
  - In contrast, the method we will see next is suboptimal, but leads to more efficient and stable solutions

## The autocorrelation method

- The autocorrelation function of a signal can be defined as

$$R(n) = \sum_{m=-\infty}^{\infty} y[m]y[n - m]$$

- This expression is similar to that of  $\phi(j, k)$  in the covariance method but extends over to  $\pm\infty$  rather than to the range  $0 \leq n < N$

$$\phi(j, k) = \sum_{-\infty}^{\infty} y[n - j]y[n - k]$$

- To perform the calculation over  $\pm\infty$ , we window the speech signal (i.e., Hann), which sets to zero all values outside  $0 \leq n < N$
- Thus, all errors  $e[n]$  will be zero before the window and  $p$  samples after the window, and the calculation of the error over  $\pm\infty$  can be rewritten as

$$\phi(j, k) = \sum_{n=0}^{N-1+p} y[n - j]y[n - k]$$

- which in turn can be rewritten as

$$\phi(j, k) = \sum_{n=0}^{N-1-(j-k)} y[n]y[n + j - k]$$

- thus,  $\phi(j, k) = R(j - k)$
- which allows us to write  $\phi(j, 0) = \sum_{k=1}^p \phi(j, k)a_k$  as

$$R(j) = \sum_{k=1}^p R(j - k)a_k$$

- The resulting matrix

$$\begin{bmatrix} R(1) \\ R(2) \\ \vdots \\ R(p) \end{bmatrix} = \begin{bmatrix} R(0) & R(1) & \dots & R(p-1) \\ R(1) & R(0) & \dots & R(p-2) \\ \vdots & \vdots & \ddots & \vdots \\ R(p-1) & R(p-2) & \dots & R(0) \end{bmatrix} \begin{bmatrix} a_1 \\ a_2 \\ \vdots \\ a_p \end{bmatrix}$$

- is now a Toeplitz matrix (symmetric, with all elements on each diagonal being identical), which is significantly easier to invert
  - In particular, the Levinson-Durbin recursion provides a solution in  $O(p^2)$

## Speech spectral envelope and the LP filter

- The frequency response of the LP filter can be found by evaluating the transfer function on the unit circle at angles  $2\pi f / f_s$ , that is

$$|H(e^{j2\pi f / f_s})|^2 = \left| \frac{G}{1 - \sum_{k=1}^p a_k e^{-j2\pi k f / f_s}} \right|^2$$

- Remember that this all-pole filter models the resonances of the vocal tract and that the glottal excitation is captured in the residual  $e[n]$
- Therefore, the frequency response of  $1/A_p(z)$  will be smooth and free of pitch harmonics
- This response is generally referred to as the spectral envelope

## How many LP parameters should be used?

- The next slide shows the spectral envelope for  $p = \{12, 40\}$ , and the reduction in mean-squared error over a range of values
  - At  $p = 12$  the spectral envelope captures the broad spectral peaks (i.e. the harmonics), whereas at  $p = 40$  the spectral peaks also capture the harmonic structure
  - Notice also that the MSE curve flattens out above about  $p = 12$  and then decreases modestly after
- Also consider the various factors that contribute to the speech spectra
  - Resonance structure comprising about one resonance per 1Khz, each resonance needing one complex pole pair
  - A low-pass glottal pulse spectrum, and a high-pass filter due to radiation at the lips, which can be modeled by 1-2 complex pole pairs
  - This leads to a rule of thumb of  $p = 4 + f_s/1000$ , or about 10-12 LP coefficients for a sampling rate of  $f_s = 8kHz$

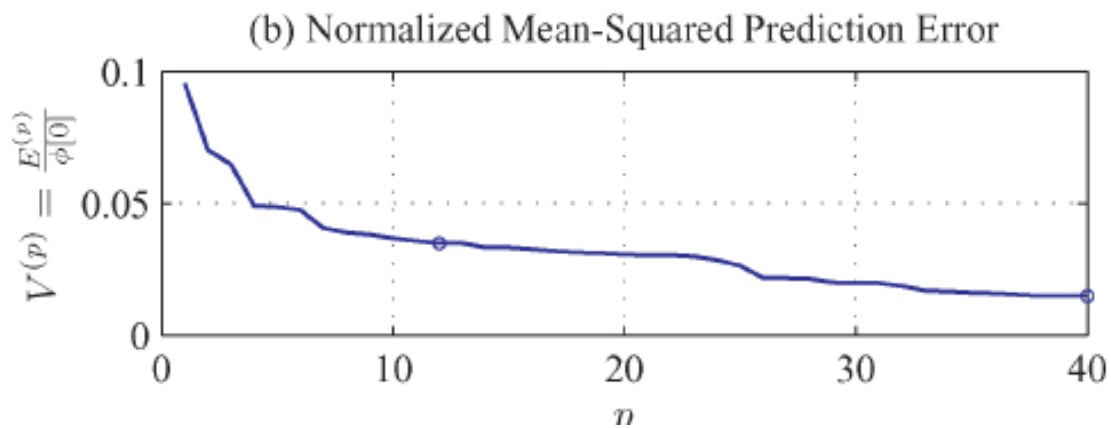
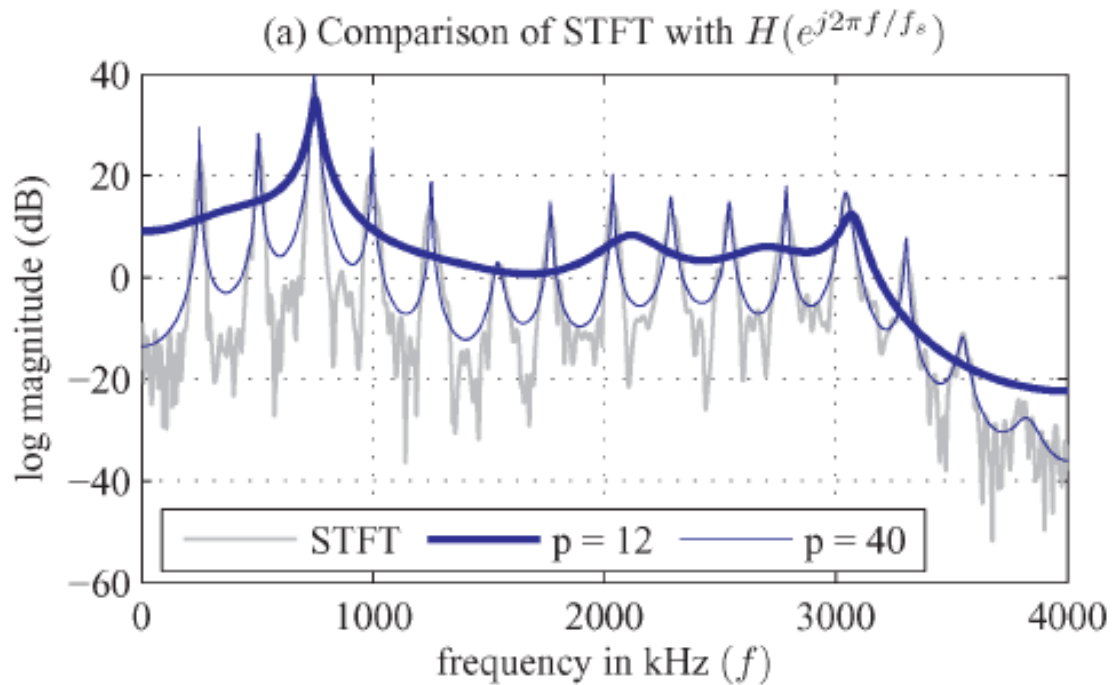

[Rabiner and Schafer, 2007]



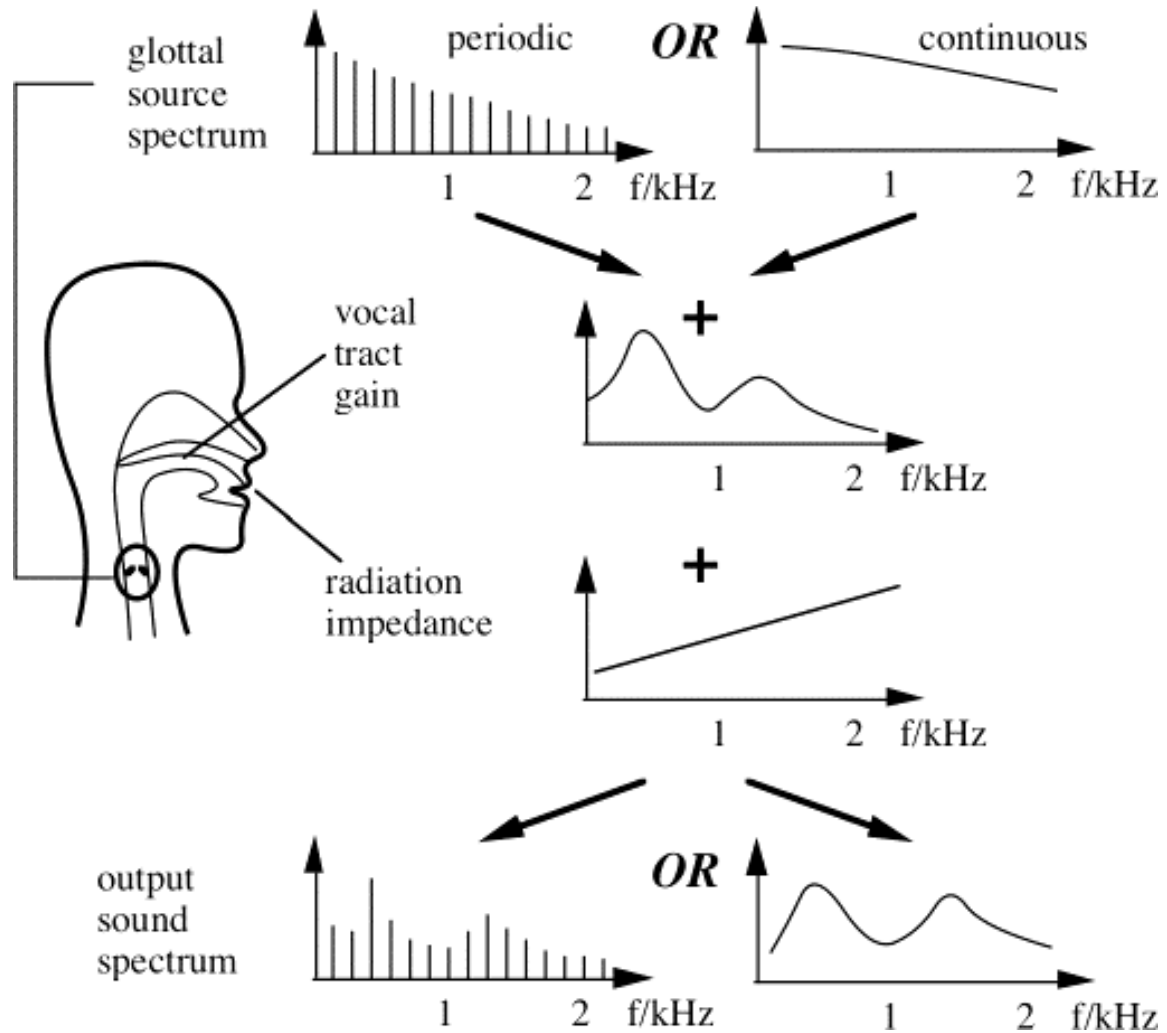

<http://www.phys.unsw.edu.au/jw/graphics/voice3.gif>

# Examples

## ex7p1.m

- Computing linear predictive coefficients
- Estimating spectral envelope as a function of the number of LPC coefficients
- Inverse filtering with LPC filters
- Speech synthesis with simple excitation models (white noise and pulse trains)

## ex7p2.m

- Repeat the above at the sentence level

# Alternative representations

## **A variety of different equivalent representations can be obtained from the parameters of the LP model**

- This is important because the LP coefficients  $\{a_i\}$  are hard to interpret and also too sensitive to numerical precision
- Here we review some of these alternative representations and how they can be derived from the LP model
  - Root pairs
  - Line spectrum frequencies
  - Reflection coefficients
  - Log-area ratio coefficients
- Additional representations (i.e., cepstrum, perceptual linear prediction) will be discussed in a different lecture

## Root pairs

- The polynomial can be factored into complex pairs, each of which represents a resonance in the model
  - These roots (poles of the LP transfer function) are relatively stable and are numerically well behaved
- The example in the next slide shows the roots (marked with a  $\times$ ) of a 12-th order model
  - Eight of the roots (4 pairs) are close to the unit circle, which indicates they model formant frequencies
  - The remaining four roots lie well within the unit circle, which means they only provide for the overall spectral shaping due to glottal and radiation influences

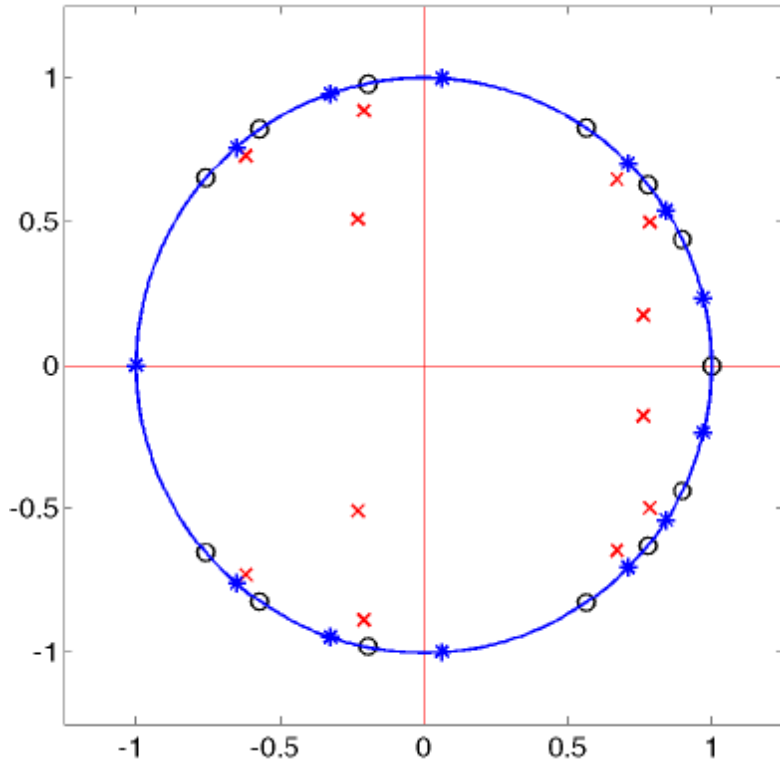

[Rabiner and Schafer, 2007]

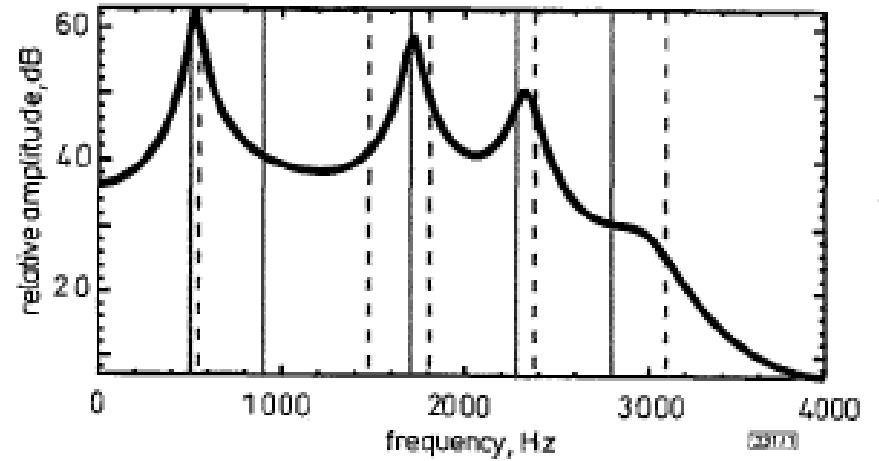

Fig. 1 LPC spectral speech frame with LSPs overlaid

[McLoughlin and Chance, 1997]

## Line spectral frequencies (LSF)

- A more desirable alternative to quantization of the roots of  $A_p(z)$  is based on the so-called line spectrum pair polynomials

$$P(z) = A(z) + z^{-(p+1)}A(z^{-1})$$

$$Q(z) = A(z) - z^{-(p+1)}A(z^{-1})$$

- which, when added up, yield the original  $A_p(z)$
- The roots of  $P(z)$ ,  $Q(z)$  and  $A_p(z)$  are shown in the previous slide
  - All the roots of  $P(z)$  and  $Q(z)$  are on the unit circle and their frequencies (angles in the  $z$ -plane) are known as the line spectral frequencies
  - The LSFs are close together when the roots of  $A_p(z)$  are close to the unit circle; in other words, presence of two close LSFs is indicative of a strong resonance (see previous slide)
  - LSFs are not overly sensitive to quantization noise and are also stable, so they are widely used for quantizing LP filters

## Reflection coefficients (a.k.a. PARCOR)

- The reflection coefficients represent the fraction of energy reflected at each section of a non-uniform tube model of the vocal tract
- They are a popular choice of LP representation for various reasons
  - They are easily computed as a by-product of the Levinson-Durbin iteration
  - They are robust to quantization error
  - They have a physical interpretation, making them amenable to interpolation
- Reflection coefficients may be obtained from the predictor coefficients through the following backward recursion

$$r_i = a_i^i \quad \forall i = p, \dots, 1$$
$$a_j^{i-1} = \frac{a_j^i + r_i a_{i-j}^i}{1 - r_i^2} \quad 1 \leq j < i$$

- where we initialize  $a_i^p = a_i$

## Log-area ratios

- Log-area ratio coefficients are the natural logarithm of the ratio of the areas of adjacent sections of a lossless tube equivalent to the vocal tract (i.e., both having the same transfer function)
  - While it is possible to estimate the ratio of adjacent sections, it is not possible to find the absolute values of those areas

- Log-area ratios can be found from the reflection coefficients as

$$A_k = \ln \left( \frac{1 - r_k}{1 + r_k} \right)$$

- where  $g_k$  is the LAR and  $r_k$  is the corresponding reflection coefficient